

## Topic A Multiple Choice Questions

### Questions on a gray background are for HL students

- 1 Two cyclists X and Y are separated by a distance of 68 km. At  $t = 0$ , X starts cycling with speed  $8.0 \text{ km hr}^{-1}$  and one hour later Y starts cycling with speed  $12 \text{ km hr}^{-1}$ .

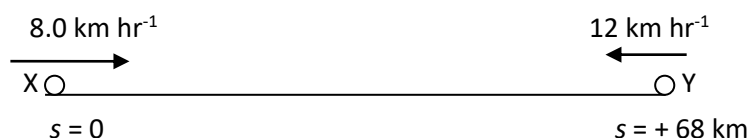

What is the displacement of Y when X and Y meet?

- A 32 km  
B  $-32 \text{ km}$   
C 36 km  
D  $-36 \text{ km}$
- 2 A car has an initial velocity  $20 \text{ m s}^{-1}$ . It decelerates at  $5.0 \text{ m s}^{-2}$ . After which distance will the car stop?  
A 4.0 m                      B 40 m                      C 80 m                      D 100 m
- 3 A small plane takes off at a speed of  $30 \text{ m s}^{-1}$  after accelerating from rest on a runway for 900 m. What is the acceleration of the plane on the runway?  
A  $0.50 \text{ m s}^{-2}$                       B  $1.0 \text{ m s}^{-2}$                       C  $3.0 \text{ m s}^{-2}$                       D  $4.0 \text{ m s}^{-2}$
- 4 An object with initial speed  $2.0 \text{ m s}^{-1}$  accelerates uniformly to a speed of  $8.0 \text{ m s}^{-1}$  in 4.0 s. What is the distance covered?  
A 8.0 m                      B 16 m                      C 20 m                      D 32 m

- 5 A block accelerating on a straight line with constant acceleration  $a$  increases its speed from  $u$  to  $v$  in a time  $t$ . The following are suggested expressions for the displacement of the block during this time:

I  $\frac{v^2 - u^2}{2a}$

II  $ut + \frac{1}{2}at^2$

III  $vt - \frac{1}{2}at^2$

Which of the following are correct expressions for the displacement?

- A I and II  
 B I and III  
 C II and III  
 D I, II and III
- 6 The graph shows the variation with time of the velocity of an object.

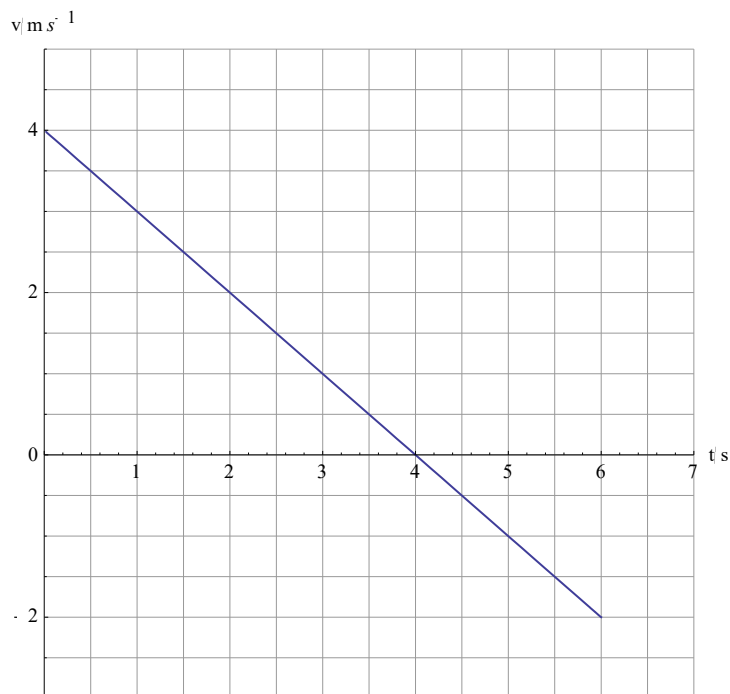

What is the distance and displacement after 6.0 s?

	Distance/m	Displacement/m
A	6	6
B	6	10
C	10	6
D	10	10

- 7 A ping-pong ball is released from rest and falls vertically. The ball attains terminal speed. Which graph shows the variation of the position of the ball with time?

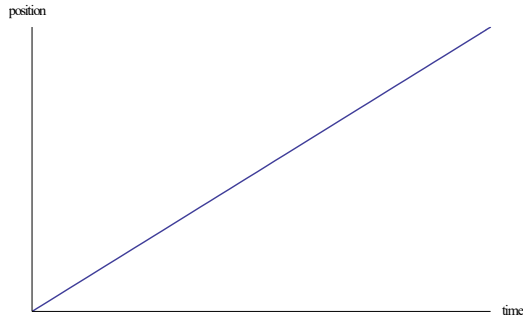

A

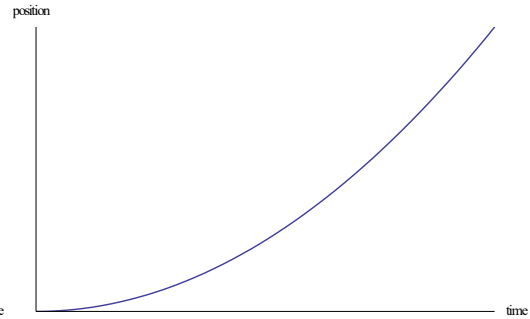

B

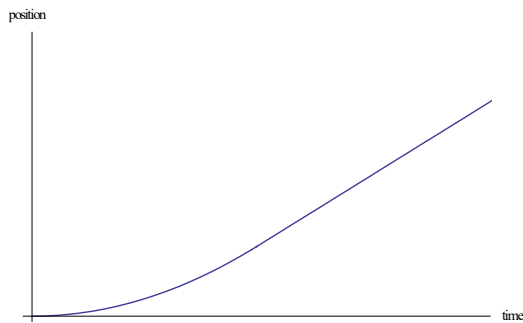

C

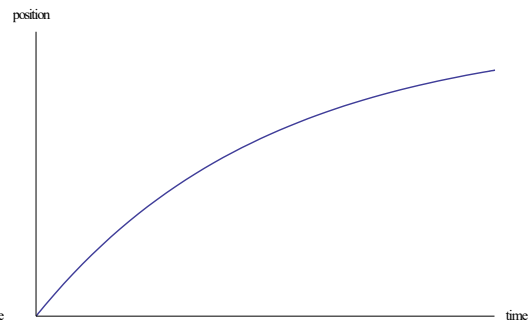

D

- 8 The graph shows how the position of an object varies with time. The shape of the graph is a parabola.

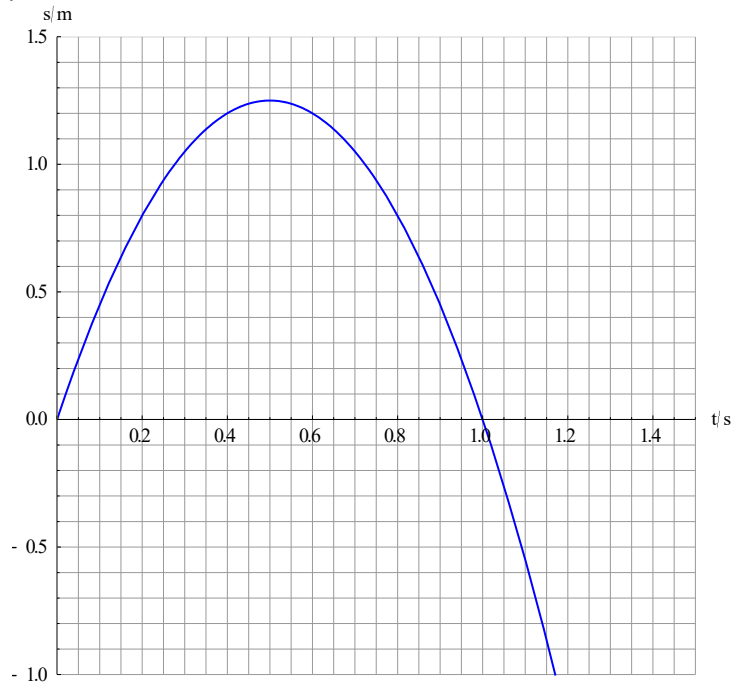

What is correct about the acceleration of the object?

- A It is zero.  
 B It is constant and positive.  
 C It is constant and negative.  
 D The acceleration is not zero and not constant.
- 9 On Earth, a stone takes time  $T$  to fall from rest a certain vertical distance and impacts the surface with speed  $v$ . What would the time of fall and impact speed be when the stone falls the same vertical distance on a planet where the acceleration of free fall is  $\frac{g}{4}$ ?

	Time to fall	Impact speed
A	$2T$	$\frac{v}{2}$
B	$2T$	$\frac{v}{4}$
C	$4T$	$\frac{v}{2}$
D	$4T$	$\frac{v}{4}$

- 10 An object thrown vertically upwards reaches a maximum height  $H$ . The same object is thrown upwards with the same speed on a planet where the acceleration of free fall is  $\frac{g}{3}$ . What is the maximum height attained?

A  $\frac{H}{3}$       B  $\frac{H}{\sqrt{3}}$       C  $H\sqrt{3}$       D  $3H$

- 11 On Earth the magnitude of the acceleration of free fall is  $g = 9.8 \text{ ms}^{-2}$ . A ball is thrown upwards and after reaching its maximum height falls down again. Taking the upward direction as positive, what is correct about the acceleration of the ball during its motion?

	Ball moving upward	Ball at maximum height	Ball moving downward
A	$g$	zero	$-g$
B	$-g$	$-g$	$-g$
C	$-g$	zero	$g$
D	$g$	$g$	$g$

- 12 Two balls are thrown with the same initial speed of  $20 \text{ m s}^{-1}$  from the same height  $h$  above ground. One ball is thrown upwards and the other downwards.

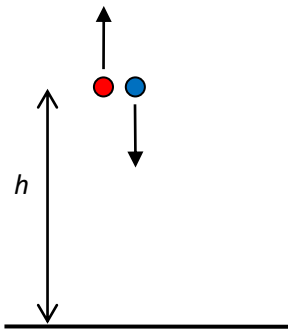

What is the time between the arrivals of the balls on the ground?

- A 1 s  
 B 2 s  
 C 4 s  
 D Impossible to answer without knowing  $h$ .
- 13 A projectile is launched horizontally from a vertical cliff with a speed  $30 \text{ m s}^{-1}$ . The cliff is 80 m high. How far from the base of the cliff does the projectile land?
- A 240 m      B 120 m      C 90 m      D 80 m

- 14 A projectile is launched at an angle to the horizontal at  $t = 0$ . At  $t = 1$  s and  $t = 3$  s the height of the projectile is the same. What is the maximum height reached by this projectile?

A 10 m      B 20 m      C 30 m      D 40 m

- 15 A projectile is launched horizontally from a cliff and hits the ground 5.0 s later. How high is the cliff?

A 125 m  
 B 75 m  
 C 50 m  
 D cannot be determined without knowing the launch speed

- 16 Two projectiles, X and Y, are launched horizontally. X is launched with speed  $v_x$  from a height  $4h$  and Y with speed  $v_y$  from a height  $h$ .

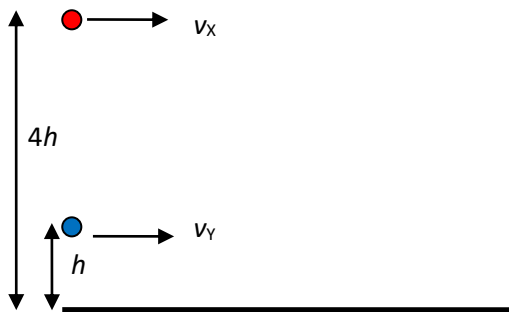

X and Y land at the same point on horizontal ground. What is the ratio  $\frac{v_x}{v_y}$  ?

A  $\frac{1}{4}$       B  $\frac{1}{2}$       C 2      D 4

- 17 A projectile is projected at  $45^\circ$  to the horizontal with kinetic energy  $K$ . What is the kinetic energy of the projectile at the highest point of its path?

A 0      B  $\frac{K}{4}$       C  $\frac{K}{2}$       D  $\frac{K}{\sqrt{2}}$

- 18 The maximum range of a projectile on Earth is  $R$ . The same projectile is projected with the same velocity on a planet where the acceleration of free fall is  $2g$ . What is the maximum range on this planet?

A  $R\sqrt{2}$       B  $\frac{R}{4}$       C  $\frac{R}{2}$       D  $\frac{R}{\sqrt{2}}$

- 19 A projectile is projected at  $45^\circ$  to the horizontal. The magnitude of its momentum at launch is  $p$ . What is the magnitude of its momentum at the highest point of its path?

A 0            B  $\frac{p}{4}$             C  $\frac{p}{2}$             D  $\frac{p}{\sqrt{2}}$

- 20 Two projectiles are launched at the same time and with the same speed at different angles to the horizontal. The graph shows the path of each projectile. Air resistance is negligible.

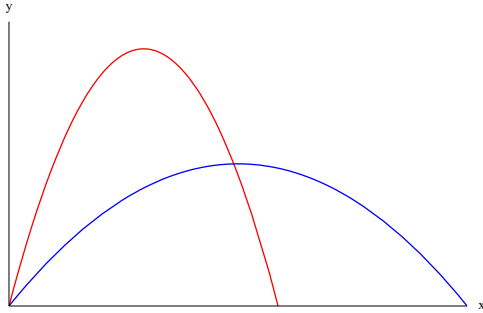

Which is correct about which projectile reaches the ground first?

- A Both reach the ground at the same time.  
B The blue projectile reaches the ground first.  
C The red projectile reaches the ground first.  
D Cannot be determined with the information given.

21 The diagram shows three forces acting on a pendulum bob. The bob is in equilibrium.

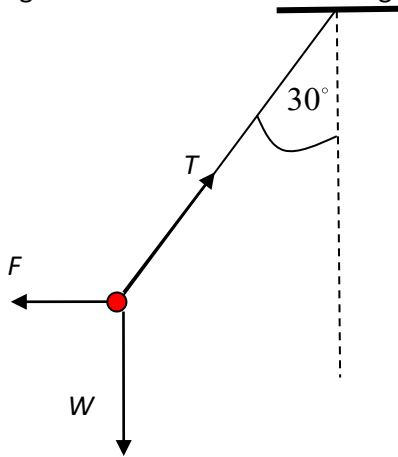

Which relation is correct?

- A  $F + W = T$
- B  $F^2 + W^2 = T^2$
- C  $F = T \cos 30^\circ$
- D  $W = T \sin 30^\circ$

22 A block connected by a string to a spring balance is placed on top of a rotating wheel as shown in the diagram.

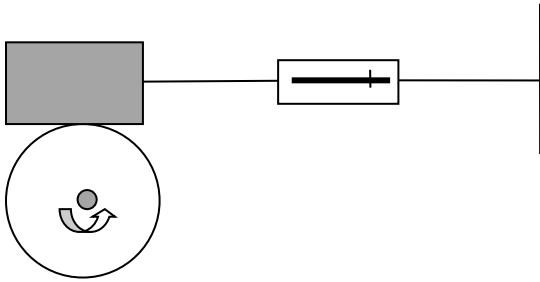

This apparatus as set up may be used to measure

- A the force of static friction between the block and the disc.
- B the force of kinetic friction between the block and the wheel.
- C the normal reaction between the block and the disc.
- D the weight of the block.

- 23 Two strings support a block of weight 100 N as shown. The angle between the strings is a right angle.

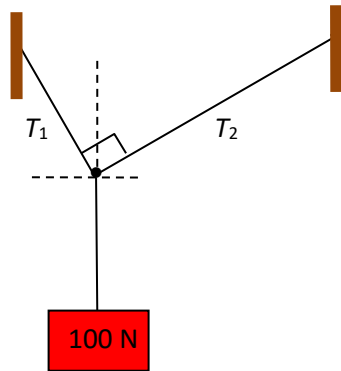

What is a possible set of values for the tensions  $T_1$  and  $T_2$ ?

	$T_1$	$T_2$
A	40 N	60 N
B	60 N	40 N
C	60 N	80 N
D	80 N	60 N

- 24 Two blocks of weight 5 N and 3 N are joined by a string and are suspended as shown.

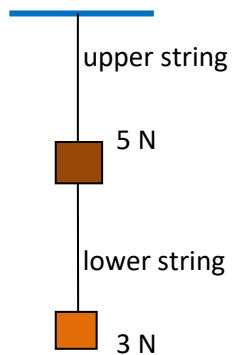

What is the tension in the lower and upper string?

	lower string	upper string
A	2 N	5 N
B	2 N	8 N
C	3 N	5 N
D	3 N	8 N

- 25 Two vectors,  $\vec{b}$  and  $\vec{r}$ , are shown. What is the vector  $\vec{b} + \vec{r}$  and what is the vector  $\vec{b} - \vec{r}$ ?

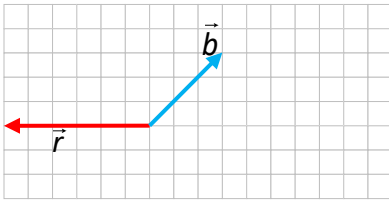

	$\vec{b} + \vec{r}$	$\vec{b} - \vec{r}$
A		
B		
C		
D		

- 26 A raindrop of radius  $r$  falls vertically through air at constant speed. The only forces on the raindrop are its weight and the viscous drag. The density of water is  $\rho$  and the viscosity of air is  $\eta$ . What is the velocity of the raindrop?

A  $\frac{2g\rho r^2}{9\eta}$       B  $\frac{2g\rho r}{3\eta}$       C  $\frac{g\rho r}{6\eta}$       D  $\frac{g\rho r^2}{9\eta}$

- 27 A rectangular block of wood floats in water as shown. The density of water is  $\rho$ .

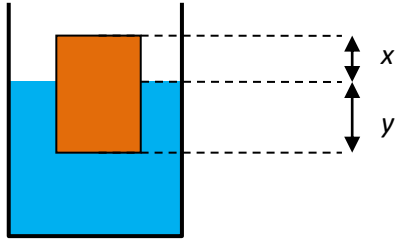

What is the density of the wood?

- A  $\frac{x}{y}\rho$       B  $\frac{x}{x+y}\rho$       C  $\frac{y}{x}\rho$       D  $\frac{y}{x+y}\rho$
- 28 A block of mass 8.0 kg rests on a rough horizontal table. The block is connected by a string that goes over a pulley to another block. The largest mass of the hanging block for which equilibrium holds is 2.0 kg.

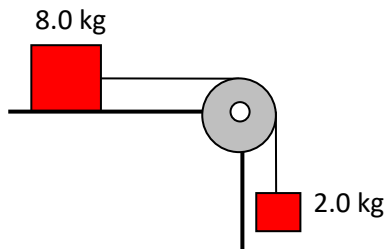

Three statements are made for this situation:

- I      The frictional force on the 8.0 kg block is 20 N.  
 II     The frictional force is the maximum frictional force.  
 III    The static coefficient of friction is 0.25.

Which is correct?

- A      I and II  
 B      I and III  
 C      II and III  
 D      I, II and III

- 29 A block of mass 5.0 kg rests on a rough horizontal table. The static coefficient of friction between the block and the table is 0.40 and the kinetic coefficient is 0.30. The block is connected by a string that goes over a pulley to a hanging block of mass  $m$ .

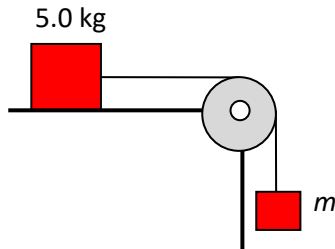

What is the largest value of  $m$  for which equilibrium holds?

- A 1.5 kg                      B 2.0 kg                      C 5.0 kg                      D 7.0 kg
- 30 A block of mass  $M$  rests on a rough inclined plane. The coefficient of static friction between the block and the incline is  $\mu$ . The plane makes an angle  $\theta$  with the horizontal. The block is connected to a hanging block of mass  $m$  through a string that goes over a pulley.

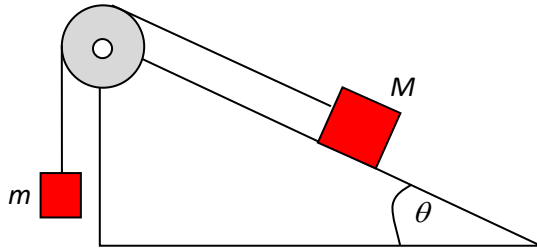

What is the minimum and maximum value of  $m$  for which we have equilibrium?

	Minimum $m$	Maximum $m$
A	$M(\sin\theta - \mu\cos\theta)$	$M(\sin\theta + \mu\cos\theta)$
B	$M(\sin\theta - \mu\cos\theta)$	$M(\cos\theta + \mu\sin\theta)$
C	$M(\cos\theta - \mu\sin\theta)$	$M(\sin\theta + \mu\cos\theta)$
D	$M(\cos\theta - \mu\sin\theta)$	$M(\cos\theta + \mu\sin\theta)$

- 31 A body of mass 5.0 kg falls vertically. The body experiences a constant air resistance force of 30 N. What is the acceleration of the body?

- A 0                              B  $4.0 \text{ m s}^{-2}$                       C  $6.0 \text{ m s}^{-2}$                       D  $10 \text{ m s}^{-2}$

- 32** A horizontal force of 12 N is applied to a block of mass 2.0 kg on a rough horizontal track. The acceleration of the block is  $3.0 \text{ m s}^{-2}$ . What is the acceleration when the pulling force is doubled?

A  $3.0 \text{ m s}^{-2}$                       B  $6.0 \text{ m s}^{-2}$                       C  $9.0 \text{ m s}^{-2}$                       D  $12 \text{ m s}^{-2}$

- 33** Two blocks are joined by a string and hang at the end of a spring of negligible mass.

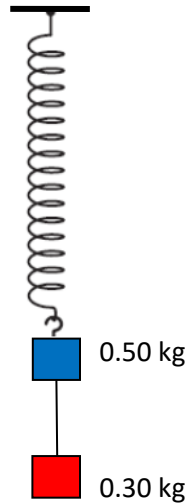

The string is cut. What is the initial acceleration of the upper block?

A  $4.0 \text{ m s}^{-2}$     B  $6.0 \text{ m s}^{-2}$     C  $9.0 \text{ m s}^{-2}$     D  $16 \text{ m s}^{-2}$

- 34** A block of mass 2.0 kg is on top of a block of mass 4.0 kg. When a force of 12 N is applied to the smaller block, both blocks accelerate but there is sliding between the blocks. The kinetic coefficient of friction between the blocks is 0.30. The ground is frictionless.

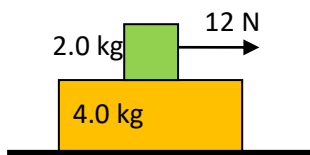

What is the acceleration of each block?

	<b>2.0 kg block</b>	<b>4.0 kg block</b>
A	$3.0 \text{ m s}^{-2}$	$1.5 \text{ m s}^{-2}$
B	$2.0 \text{ m s}^{-2}$	$2.0 \text{ m s}^{-2}$
C	$2.0 \text{ m s}^{-2}$	$3.0 \text{ m s}^{-2}$
D	$3.0 \text{ m s}^{-2}$	$3.0 \text{ m s}^{-2}$

- 35 A block of mass  $m$  is released on a frictionless inclined plane. The acceleration of the block when on the inclined plane is  $a$  and the speed of the block when it reaches level ground is  $v$ . A second block of mass  $2m$  is released from the same height on the same inclined plane. What are the corresponding speed and acceleration?

	speed	acceleration
A	$\frac{v}{2}$	$\frac{a}{2}$
B	$v$	$\frac{a}{2}$
C	$\frac{v}{2}$	$a$
D	$v$	$a$

- 36 Two blocks of mass 3.0 kg and 6.0 kg are connected by a string on a horizontal frictionless table. A force of 18 N acts on the 6.0 kg block. What is the tension in the string?

A 0                      B 6.0 N                      C 12 N                      D 18 N

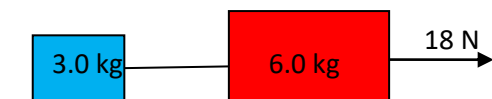

- 37 A man of mass 70 kg stands in an elevator that moves downwards with deceleration  $2.0 \text{ m s}^{-2}$ . What is the force exerted on the man by the elevator floor?

A 0 N                      B 140 N                      C 560 N                      D 840 N

- 38 The drag force on a sphere falling through air is  $F_D = c\rho v^2$  where  $c$  is a constant and  $\rho$  is the density of air. A sphere of weight 20 N falling through air reaches a terminal speed of  $30 \text{ m s}^{-1}$ . What is the drag force on the same body when it is moving at  $15 \text{ m s}^{-1}$  through air?

A 5 N                      B 10 N                      C 20 N                      D 80 N

- 39** The graph shows how the net force on a body varies with time. The body has an initial velocity in the direction of the force.

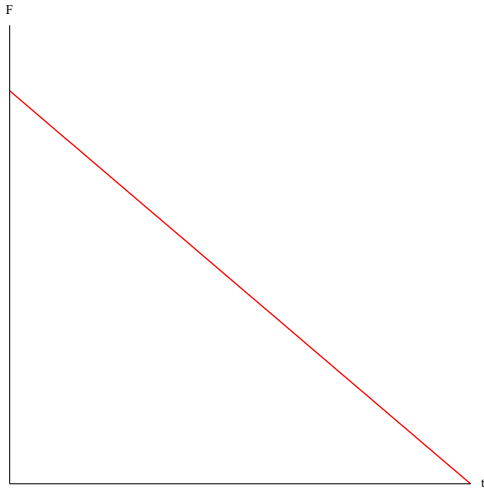

Which graph shows the variation with time of the velocity of the body?

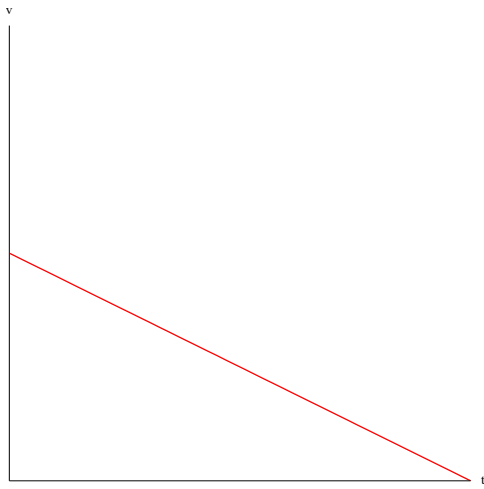

**A**

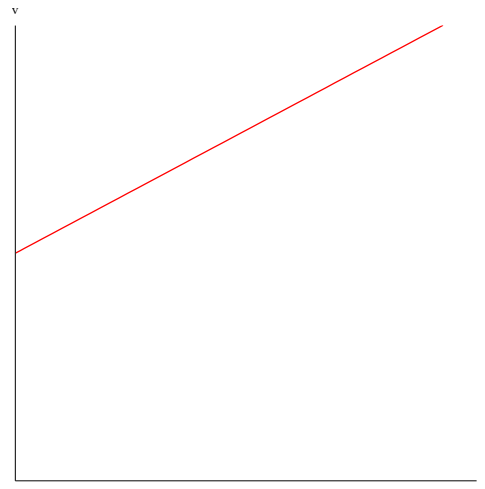

**B**

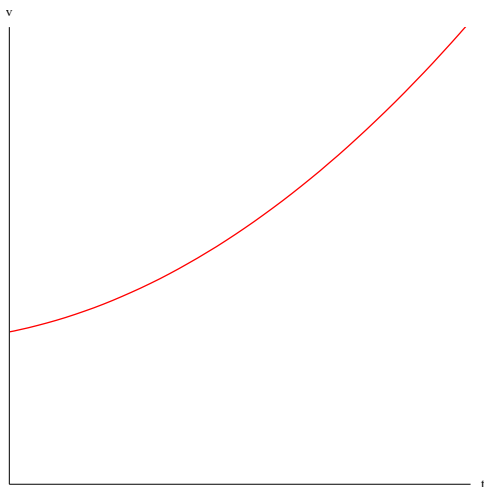

**C**

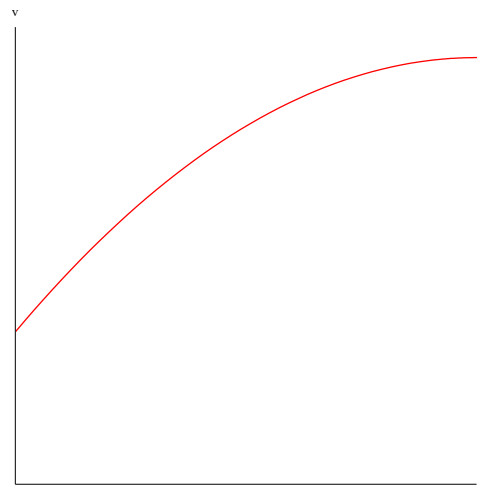

**D**

- 40 The graph shows how the net force on a body varies with time. The body is initially at rest.

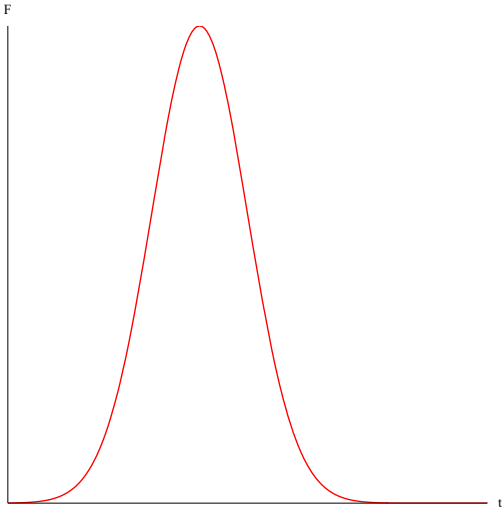

Which is the correct variation with time of the speed of the body?

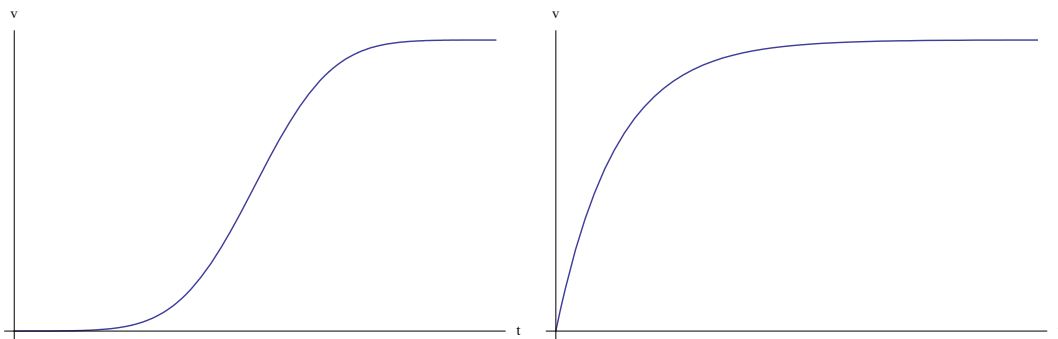

**A**

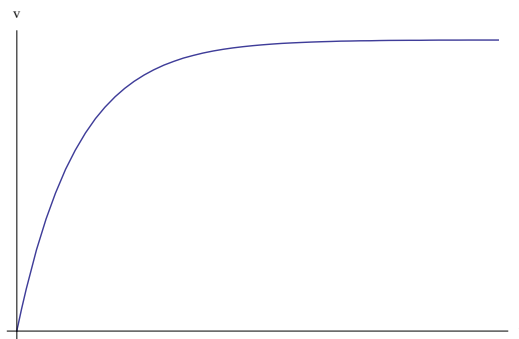

**B**

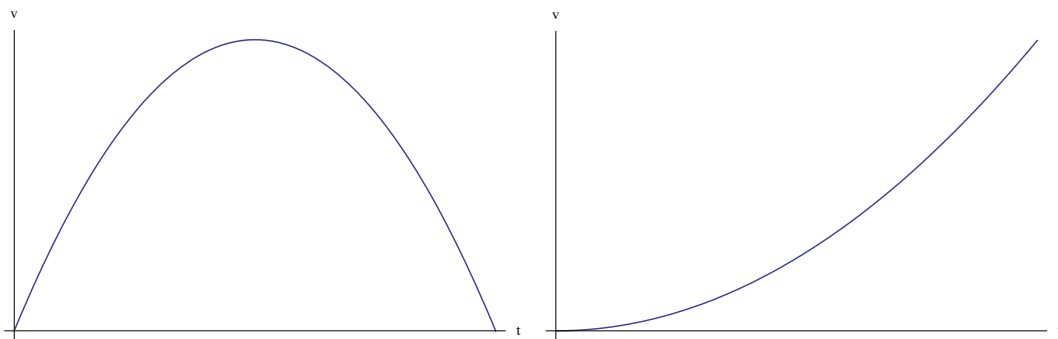

**C**

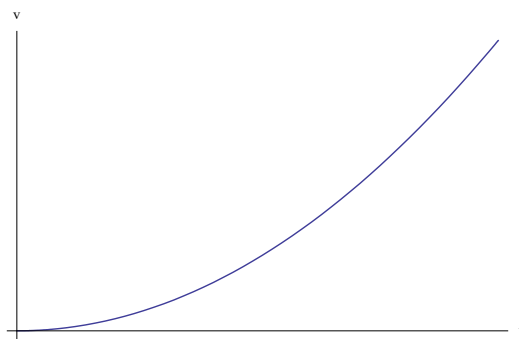

**D**

- 41 A particle moves along a circular path of radius  $R$  moving from X to Y in time  $T$ .

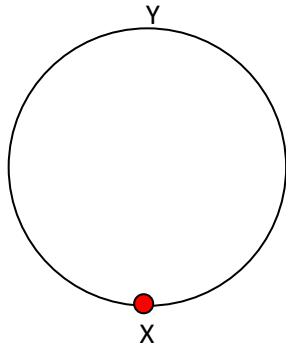

What is the average linear speed, magnitude of average velocity and average angular speed of the particle?

	Average speed	Average velocity	Average angular speed
A	$\frac{\pi R}{T}$	$\frac{2R}{T}$	$\frac{\pi}{2T}$
B	$\frac{2R}{T}$	$\frac{\pi R}{T}$	$\frac{\pi}{T}$
C	$\frac{\pi R}{T}$	$\frac{2R}{T}$	$\frac{\pi}{T}$
D	$\frac{2R}{T}$	$\frac{\pi R}{T}$	$\frac{\pi}{2T}$

- 42 A body of mass  $m$  is on a horizontal table. A string joins it with another body of mass  $M$  through a hole in the table. The mass  $m$  rotates on a horizontal circle of radius  $R$  such that  $M$  is stationary.

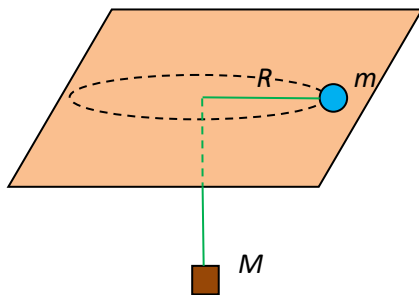

How many revolutions per second does  $m$  make?

- A  $\frac{1}{2\pi} \sqrt{\frac{Mg}{mR}}$       B  $\frac{1}{2\pi} \sqrt{\frac{mg}{MR}}$       C  $\frac{1}{4\pi^2} \frac{Mg}{mR}$       D  $\frac{1}{4\pi^2} \frac{mg}{MR}$

- 43 A particle of weight  $W$  is attached to a solid rod of length  $L$  and moves in a vertical circle with **constant** speed. The diagrams show two positions of the particle, X and Y.

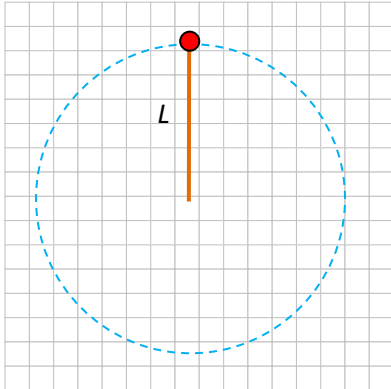

Position X

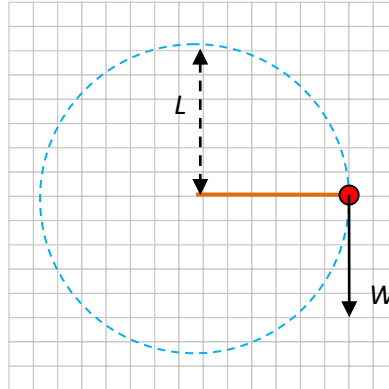

Position Y

The kinetic energy of the particle is  $K$ . What is the magnitude of the tension  $T$  in the rod at X and what is the direction of the tension force at Y?

	Magnitude of tension at X	Direction of tension at Y
A	$\frac{2K}{L} + W$	
B	$\frac{2K}{L} - W$	

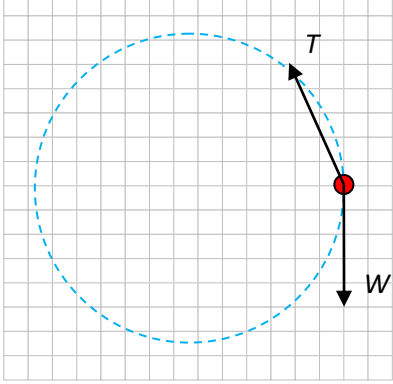
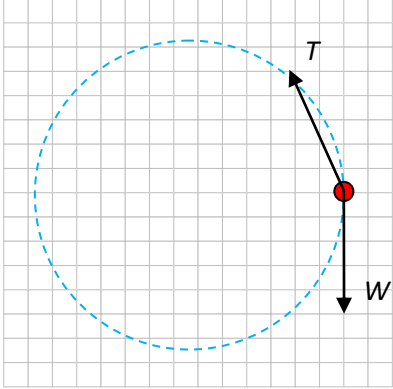
C	$\frac{2K}{L} + W$	
D	$\frac{2K}{L} - W$	

- 44 A person of mass  $m$  stands on roller skates facing a wall. After pushing against the wall with a constant force  $F$  he moves away reaching speed  $v$  after a distance  $d$ . What is the work done by  $F$ ?

A 0            B  $mv^2$             C  $\frac{1}{2}mv^2$             D  $Fd$

- 45 The power delivered by a car engine is constant. A car starts from rest. Resistance forces are negligible. Which graph shows the variation with time of the speed of the car?

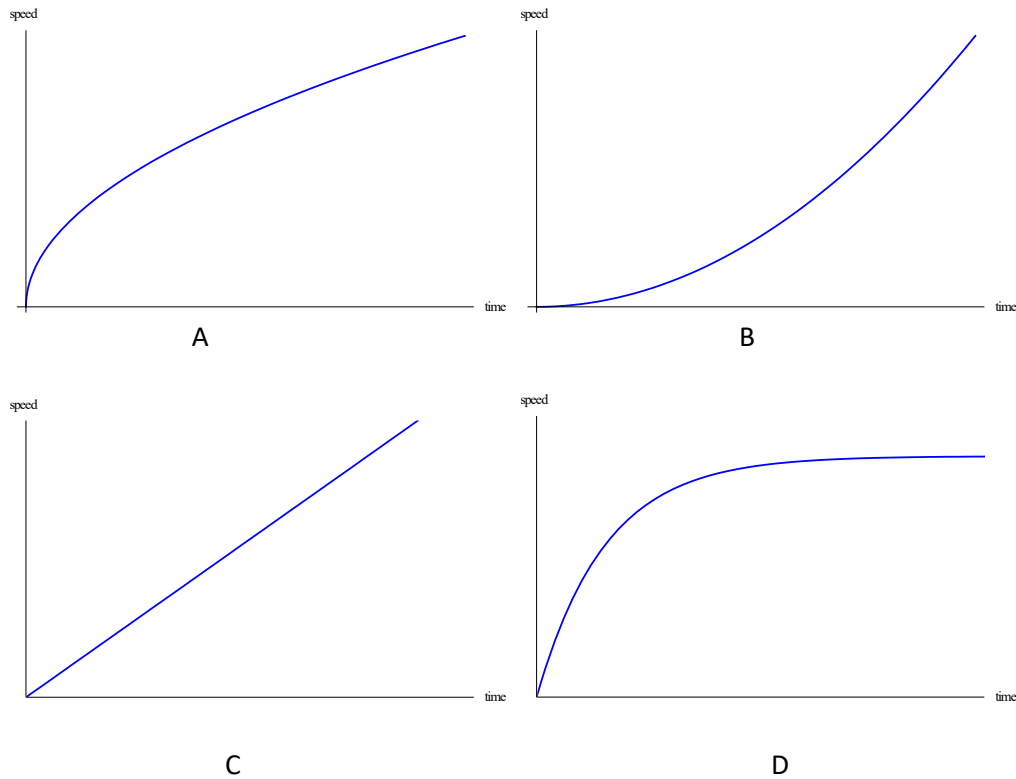

- 46 The diagram shows two identical containers, X and Y, that are connected by a thin tube of negligible volume. Initially container X is filled with water of mass  $m$  up to a height  $h$  and Y is empty.

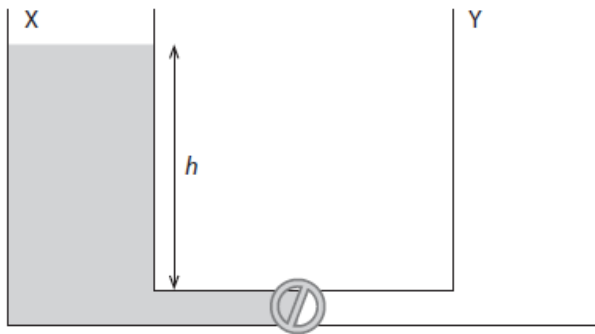

The valve is then opened and both containers contain equal quantities of water. What is the loss of gravitational potential energy of the water?

- A 0      B  $\frac{mgh}{8}$       C  $\frac{mgh}{4}$       D  $\frac{mgh}{2}$

- 47 After a body has fallen vertically by a certain distance the gravitational potential energy of the body decreased by  $\Delta E_p$  and an amount of thermal energy  $Q$  was generated. What is the change in the body's kinetic energy during this time?

A  $\Delta E_p$                       B  $\Delta E_p + Q$                       C  $\Delta E_p - Q$                       D  $Q$

- 48 A net force of 8.0 N accelerates a 4.0 kg body from rest to a speed of  $5.0 \text{ m s}^{-1}$ . What is the work done by the force?

A 20 J              B 32 J              C 40 J              D 50 J

- 49 Two blocks of mass  $M$  and  $m$  are connected by a string that goes over a pulley. The heavier block is at a height  $h$  from the ground.

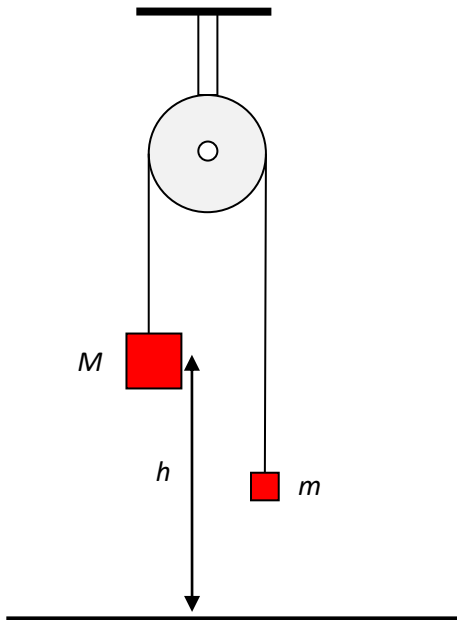

The blocks are held in place and then released. What is the speed with which the block of mass  $M$  strikes the ground?

A  $\sqrt{2gh}$               B  $\sqrt{\frac{2(M-m)gh}{M+m}}$               C  $\sqrt{\frac{2(M+m)gh}{M-m}}$               D  $\sqrt{\frac{2Mgh}{M+m}}$

- 50 A constant net force of 6.0 N accelerates a body from rest to a speed of  $8.0 \text{ m s}^{-1}$ . What is the average power developed by the force?

A 12 W

B 24 W

C 48 W

D Impossible to answer with the data given.

- 51 A constant net force  $F$  acts on a block. The initial velocity of the block is  $5.0 \text{ m s}^{-1}$  in a direction opposite to the force. After a distance  $d$  the force stops the block and after another distance  $d$  the block gets a velocity of  $-5.0 \text{ m s}^{-1}$ .

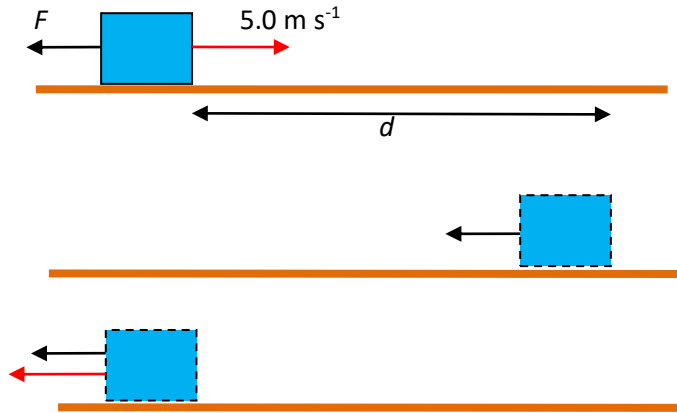

What is the total work done by  $F$  and what is the reasoning for your answer?

	work done	reasoning
A	0	The displacement of the block is zero
B	0	The change in the kinetic energy is zero
C	$2Fd$	An amount $Fd$ each way
D	$2Fd$	An amount $-Fd$ one way and $+Fd$ the other way but we add the magnitudes because work is a scalar.

- 52 The graph shows the variation of the net force on a body with the distance travelled.

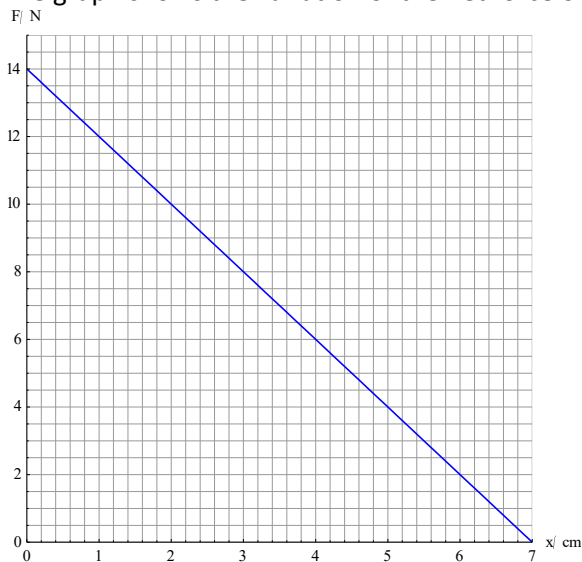

What is the change in kinetic energy of the body after 7 cm?

- A 98 J      B 49 J      C 0.98 J      D 0.49 J

- 53 A body hangs at the end of a spring. The elastic energy stored in the spring is  $E$ . The body is now attached to two springs identical to the first.

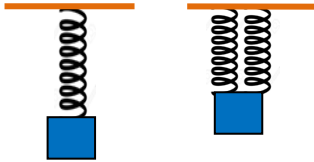

What is the total elastic energy stored in the two springs?

- A  $\frac{E}{4}$       B  $\frac{E}{2}$       C  $\frac{3E}{4}$       D  $2E$
- 54 Water is being raised from a well of depth  $d$  at a rate of  $\mu$  kg per second by a pump. What is the power developed by the pump?
- A  $\mu g$       B  $\mu g d$       C  $\frac{\mu d}{g}$       D  $\frac{\mu g}{d}$
- 55 A motor of efficiency 60% is used to raise a weight of 300 N vertically distance at constant speed  $0.80 \text{ m s}^{-1}$ . What is the input power to the motor?
- A 144 W      B 225 W      C 240 W      D 400 W
- 56 A power plant produces 500 MW of electrical power with an overall efficiency of 20%. How much power is lost?
- A 250 MW      B 1000 MW      C 2000 MW      D 2500 MW
- 57 A racing car is moving along a straight line at constant speed  $30 \text{ m s}^{-1}$ . The power of the engine is 40 kW. The air resistance force on the car is proportional to the square of the speed. What power must the engine deliver, for the car to move at  $60 \text{ m s}^{-1}$ ?
- A 40 kW      B 80 kW      C 160 kW      D 320 kW

- 58 Four balls are projected from the top of a building with equal speeds but in different directions. Which ball will get to the level ground with the least vertical component of velocity?

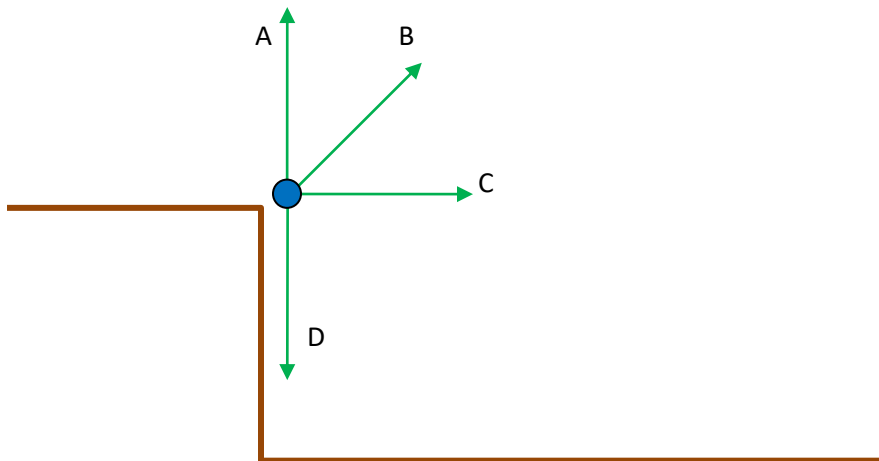

- 59 A ball of mass  $0.30 \text{ kg}$  falls vertically and impacts horizontal ground with speed  $3.0 \text{ m s}^{-1}$ . The ball rebounds vertically with speed  $2.0 \text{ m s}^{-1}$ . The ball was in contact with the ground for  $50 \text{ ms}$ . What is the average force exerted on the ground by the ball?
- A  $33 \text{ N}$       B  $30 \text{ N}$       C  $9.0 \text{ N}$       D  $6.0 \text{ N}$
- 60 The graph shows how the net force on a body of mass  $2.0 \text{ kg}$  varies with time.

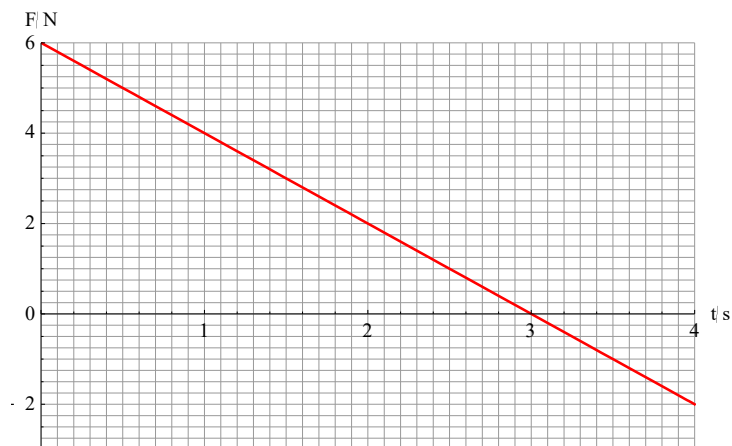

The initial velocity of the body is zero. What is the velocity of the body after  $4.0$  seconds?

- A  $4.0 \text{ m s}^{-1}$       B  $4.5 \text{ m s}^{-1}$       C  $5.0 \text{ m s}^{-1}$       D  $12 \text{ m s}^{-1}$

- 61 A ball of mass  $0.50 \text{ kg}$  travelling with speed  $4.0 \text{ m s}^{-1}$  collides with a vertical wall and bounces in the opposite direction with the same speed. What is the magnitude of the change of the momentum of the ball?

A 0                      B  $2.0 \text{ N s}$                       C  $4.0 \text{ N s}$                       D  $8.0 \text{ N s}$

- 62 Two identical blocks moving in opposite directions on a frictionless track collide and stick together. The velocities of the blocks before the collision are shown on the diagram.



What is the common velocity of the blocks after the collision?

- A  $2.5 \text{ m s}^{-1}$       B  $-2.5 \text{ m s}^{-1}$       C  $0.5 \text{ m s}^{-1}$       D  $-0.5 \text{ m s}^{-1}$
- 63 Two blocks are held together compressing a spring between them. When they are released the  $3.0 \text{ kg}$  block moves to the left with speed  $4.0 \text{ m s}^{-1}$ .

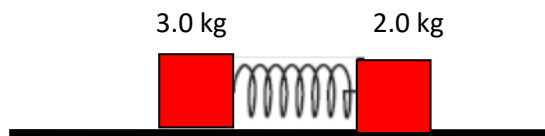

What was the energy stored in the compressed spring?

- A 12 J                      B 24 J                      C 36 J                      D 60 J
- 64 Water of density  $\rho$  is coming out of a horizontal pipe of cross sectional area  $A$  with speed  $v$ .



What horizontal force must be exerted on the pipe to keep it at rest?

- A  $\rho Av$   
 B  $\rho Av^2$   
 C  $\rho v$   
 D  $\rho v^2$

- 65 A body of mass  $m$  moves along a horizontal circle of radius  $R$  with constant speed  $v$ . What is the work done by the centripetal force during **half** a revolution?

A 0      B  $\pi R \times \frac{mv^2}{R}$       C  $R \times \frac{mv^2}{R}$       D  $2R \times \frac{mv^2}{R}$

- 66 A body accelerates from rest with constant acceleration in a straight line. Which graph shows the variation of the momentum of the body with distance travelled?

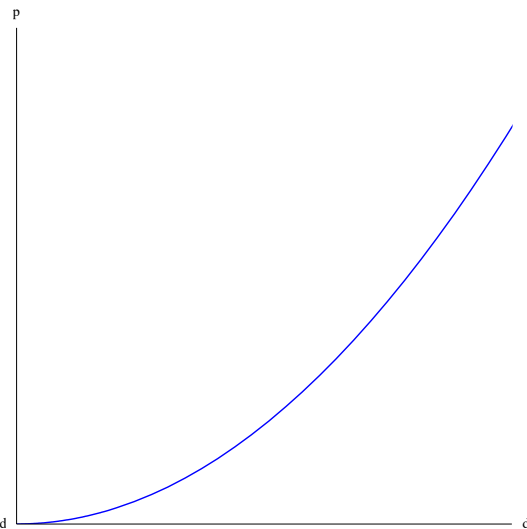
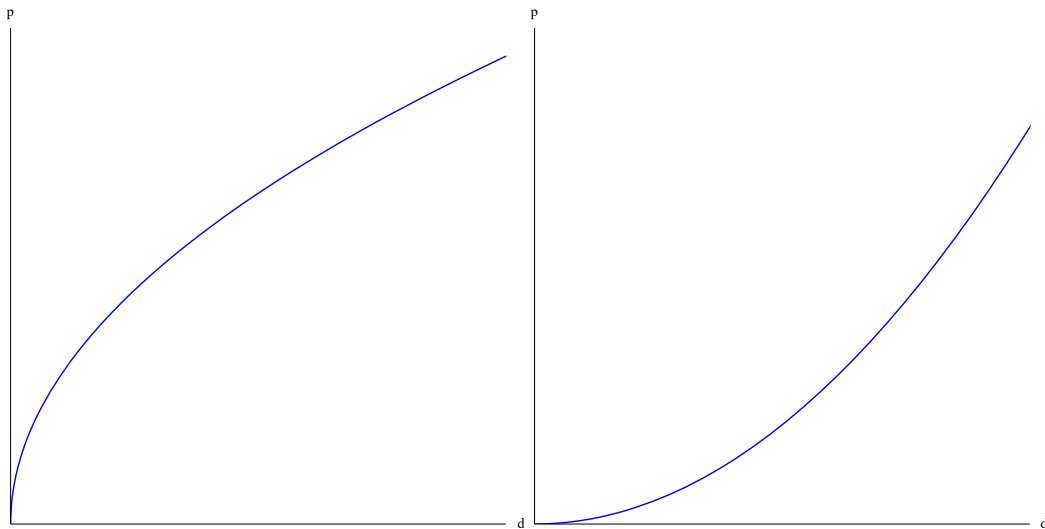
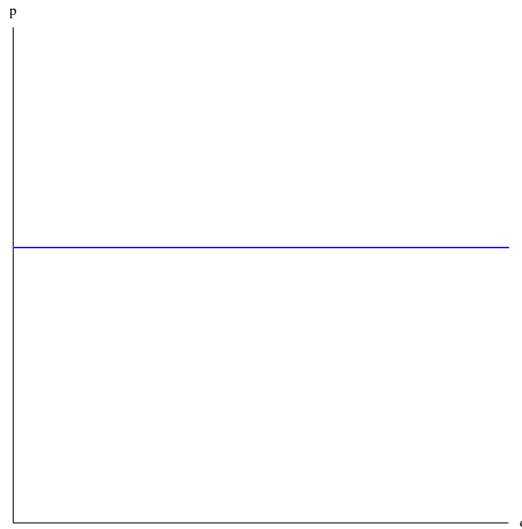
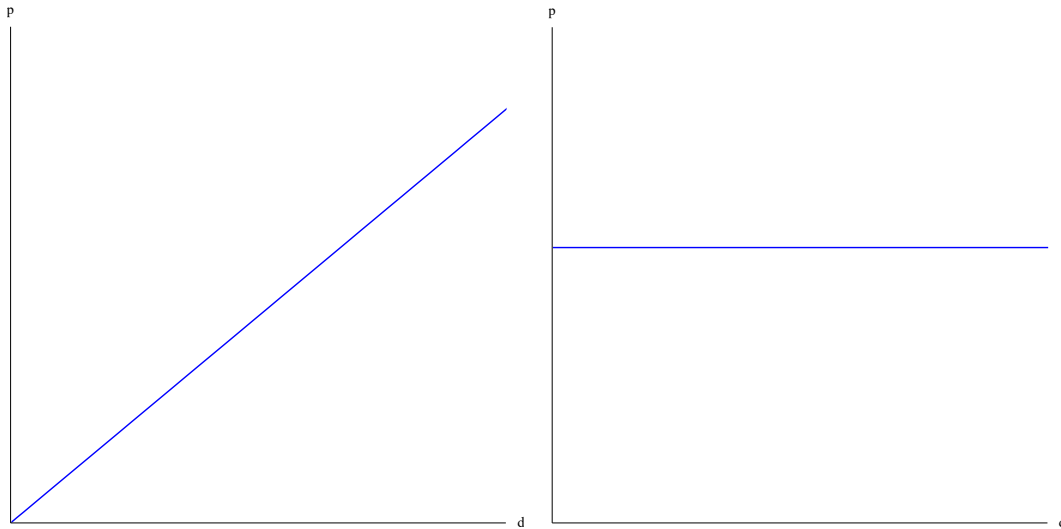

- 67 The graph shows how the net force on a body of mass 2.0 kg varies with time. The change in momentum of the body from 1 s to 4 s is 6.0 N s.

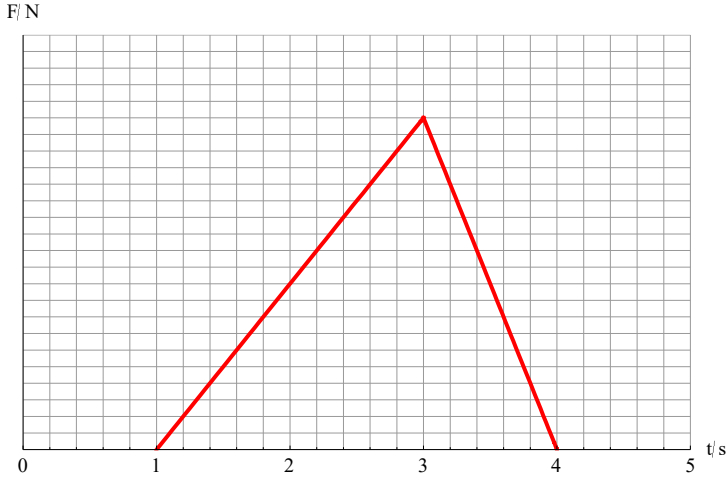

What is the maximum acceleration experienced by the body?

- A  $1.0 \text{ m s}^{-2}$     B  $2.0 \text{ m s}^{-2}$     C  $3.0 \text{ m s}^{-2}$     D  $4.0 \text{ m s}^{-2}$
- 68 A block X of mass  $m$  moves on a frictionless horizontal surface with velocity  $u$ . The block collides head-on with block Y of mass  $M$  that was initially at rest. Block X is brought to rest as a result of the collision.

What is the change in the momentum of block Y?

- A  $-mu$                       B  $mu$                       C  $-Mu$                       D  $Mu$
- 69 Which is correct about momentum and kinetic energy in an inelastic collision?

	momentum	kinetic energy
A	conserved	conserved
B	conserved	not conserved
C	not conserved	conserved
D	not conserved	not conserved

- 70 A block X of mass  $m$  moves on a frictionless horizontal surface with velocity  $v$ . The block collides head-on with block Y of larger mass  $M$  that was initially at rest. Block X is brought to rest as a result of the collision.

What fraction of the original kinetic energy is lost in this collision?

- A 0                      B  $\frac{m}{M+m}$                       C  $\frac{M-m}{M}$                       D  $\frac{m}{M}$

- 71 Two objects of mass  $m$  and  $2m$  are travelling in opposite directions with the same speed  $v$ . The objects collide and stick together. What is the kinetic energy lost in the collision?

A 0                      B  $\frac{3mv^2}{2}$                       C  $\frac{5mv^2}{6}$                       D  $\frac{4mv^2}{3}$

- 72 The diagram shows a glancing collision of two bodies of the same mass.

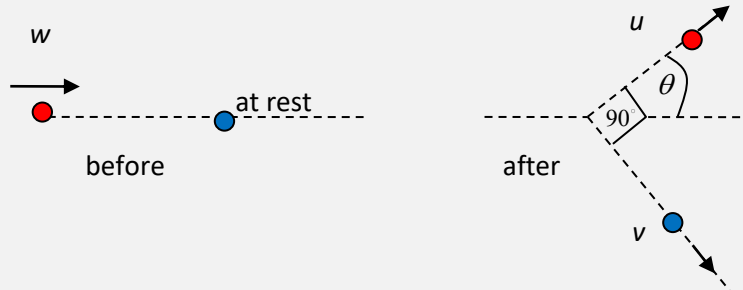

Three statements are made for this collision:

- I  $u = w \cos \theta$   
 II  $v = w \sin \theta$   
 III The collision is elastic.

Which statements are correct?

- A I and II  
 B I and III  
 C II and III  
 D I, II and III

- 73 A body of mass  $3M$  explodes at rest into two pieces of mass  $M$  and  $2M$ . What is the ratio of the kinetic energy of  $M$  to that of  $2M$ ?

A  $\frac{1}{4}$                       B  $\frac{1}{2}$                       C 2                      D 4

- 74 The momentum of a body moving along a straight line changed from  $4.0 \text{ N s}$  to  $12 \text{ N s}$  in  $2.0 \text{ s}$ . What is the impulse delivered to the body?

A  $2.0 \text{ N s}$                       B  $4.0 \text{ N s}$                       C  $8.0 \text{ N s}$                       D  $16 \text{ N s}$

- 75 A girl of mass  $m$  jumps vertically upwards. After she loses contact with the ground, her centre of mass is raised by a distance  $h$  in time  $T$ . What is the impulse delivered to the girl while she is in contact with the ground?

A  $mgT$                       B  $\frac{mgh}{T}$                       C  $mgh$                       D  $m\sqrt{2gh}$

- 76 A block of mass  $4.0 \text{ kg}$  moving horizontally at  $3.0 \text{ m s}^{-1}$  collides with a stationary block of mass  $8.0 \text{ kg}$  and bounces back with speed  $1.0 \text{ m s}^{-1}$ . What is the speed of the  $8.0 \text{ kg}$  block?

A  $1.0 \text{ m s}^{-1}$                       B  $2.0 \text{ m s}^{-1}$                       C  $3.0 \text{ m s}^{-1}$                       D  $4.0 \text{ m s}^{-1}$

- 77 The graph shows how the net force,  $F$ , on a body of mass  $2.0 \text{ kg}$  varies with time  $t$ . The body is initially at rest.

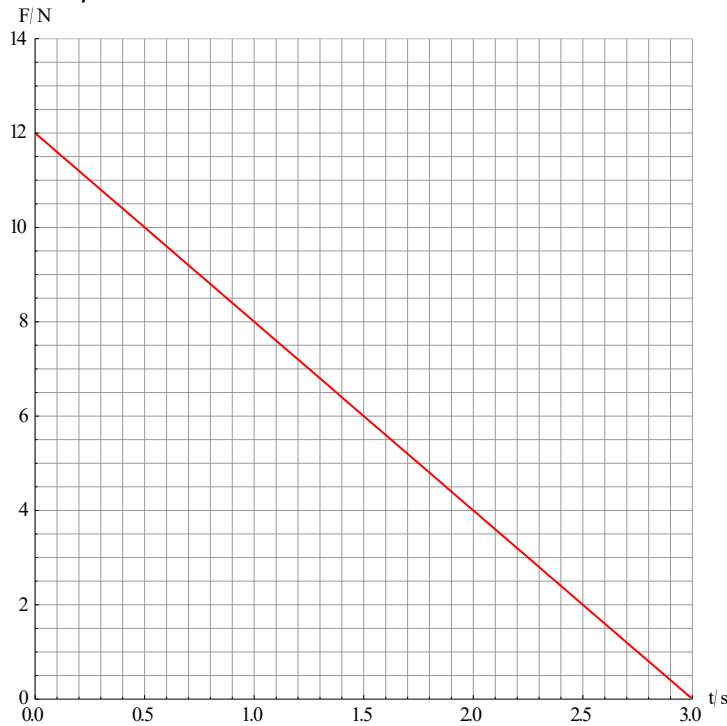

What is the average power delivered to the body from  $t = 0$  to  $t = 3 \text{ s}$ ?

A 27 W                      B 36 W                      C 54 W                      D 108 W

- 78 A disc starts to rotate from rest. After 10 revolutions the angular speed is  $20 \text{ rad s}^{-1}$ . What is the angular acceleration of the disc?

A  $0.5 \text{ rads}^{-2}$                       B  $\frac{5}{\pi} \text{ rads}^{-2}$                       C  $\frac{10}{\pi} \text{ rads}^{-2}$                       D  $10 \text{ rads}^{-2}$

- 79 A disc rotates with an angular speed  $10 \text{ rad s}^{-1}$  and has an angular acceleration of  $2.0 \text{ rad s}^{-2}$ . By what angle does the disc turn when the angular speed becomes  $30 \text{ rad s}^{-1}$ ?

A 60 rad                      B 80 rad                      C 100 rad                      D 200 rad

**80** A cylinder that is initially at rest has moment of inertia  $12 \text{ kg m}^2$ . It is acted upon by a torque of  $6 \text{ N m}$ . When will the angular speed become  $10 \text{ rad s}^{-1}$ ?

- A** 5.0 s      **B** 6.0 s      **C** 12 s      **D** 20 s

**81** A ring of mass  $M$  and radius  $R$  has moment of inertia  $MR^2$  about its axis. The ring is initially at rest on an inclined plane. What is the linear speed of the ring when its centre of mass is lowered by a vertical distance  $h$ ?

- A**  $\sqrt{\frac{gh}{2}}$       **B**  $\sqrt{gh}$       **C**  $\sqrt{2gh}$       **D**  $2\sqrt{gh}$

**82** A solid disc and a ring of the same mass and radius roll without slipping down identical inclined planes. Both objects start from rest and cover the same distance.

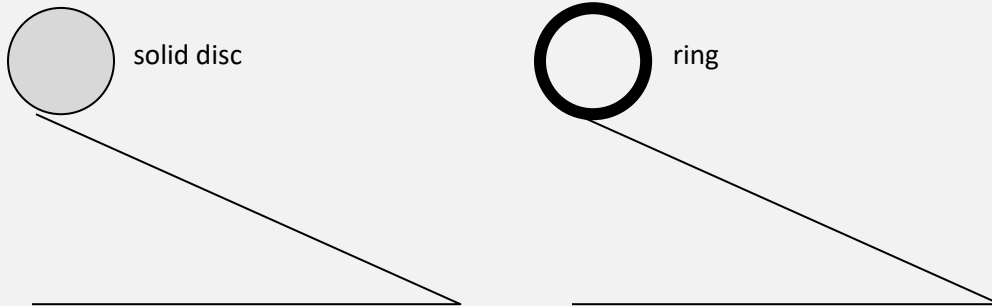

Which object will get to the bottom in the least time and which will have the greatest linear speed?

	Least time	Greatest speed
<b>A</b>	Disc	Disc
<b>B</b>	Disc	Ring
<b>C</b>	Ring	Disc
<b>D</b>	Ring	Ring

**83** A disc on a horizontal frictionless table is acted upon by two equal and opposite forces.

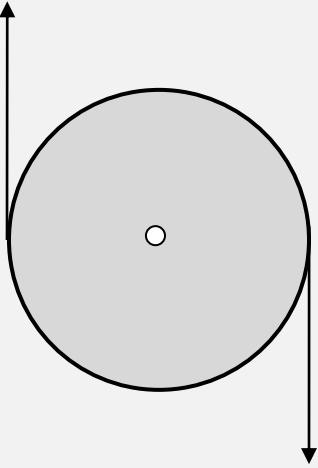

Is the disc in translational or rotational equilibrium?

	<b>Translational</b>	<b>Rotational</b>
<b>A</b>	Yes	Yes
<b>B</b>	Yes	No
<b>C</b>	No	Yes
<b>D</b>	No	No

- 84 Four forces of the same magnitude act on a body. In which case is the torque about the axis shown the least?

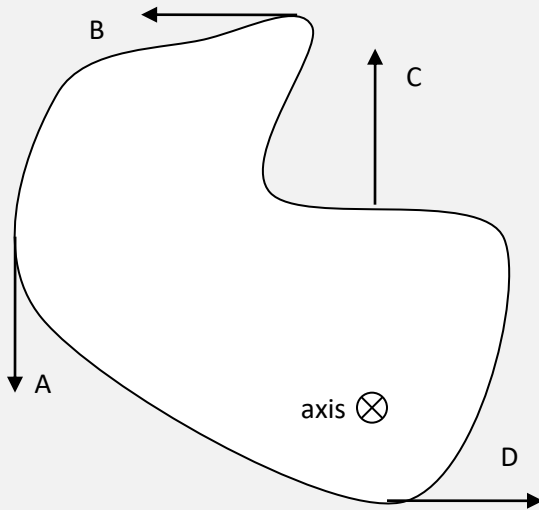

- 85 A disc rotates with angular speed  $\omega$  on a frictionless horizontal table. The moment of inertia about the vertical rotation axis is  $I$ . A mass  $m$  falls vertical on the disc and gets stuck at a distance  $d$  from the centre. What is the new angular speed of the disc?

A  $\frac{I\omega}{I+md^2}$

B  $\frac{I\omega}{md^2}$

C  $\frac{(I+md^2)\omega}{I}$

D  $\frac{md^2\omega}{I}$

86. A rigid body of moment of inertia  $I$  is rotating about an axis with angular speed  $\omega$ . A frictional torque  $\tau$  brings the body to rest. What is the number of revolutions performed by the body from the moment the torque is applied until the moment it stops moving?

A  $\frac{\omega^2 I}{2\tau}$

B  $\frac{\omega^2 I}{2\pi\tau}$

C  $\frac{\omega^2 I}{4\tau}$

D  $\frac{\omega^2 I}{4\pi\tau}$

- 87 The graph shows the variation with time of the angular speed of a body.

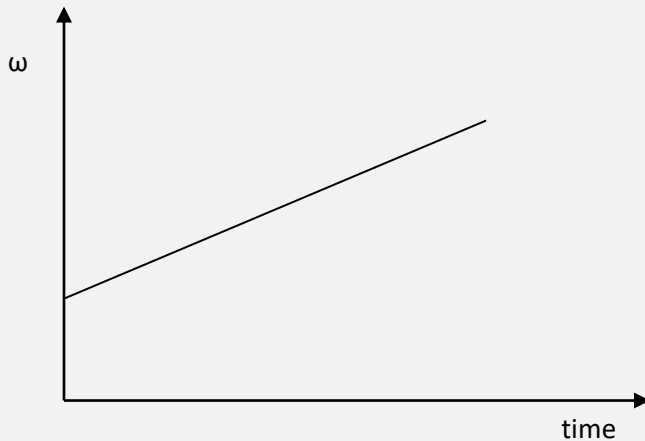

What does the slope of the line represent?

- A number of revolutions  
 B angle rotated  
 C angular acceleration  
 D linear acceleration
- 88 A cylinder of mass  $M$  and radius  $R$  rotates about its axis at constant angular speed  $\omega$ . The moment of inertia is  $\frac{1}{2}MR^2$ . The kinetic rotational energy of the cylinder is  $K$ . Another cylinder has mass  $2M$ , radius  $2R$  and rotates with angular speed  $2\omega$ . What is the rotational kinetic energy of the second cylinder?
- A  $8K$             B  $16K$             C  $32K$             D  $64K$
- 89 Two cylinders of different mass and radius start to roll without slipping from the same point on the same inclined plane. Which cylinder arrives at the base of the inclined plane first?
- A The one with the smaller radius.  
 B The one with the larger radius.  
 C Neither, it is a tie.  
 D The one with the smaller mass.

- 90 A string is wrapped around a flywheel of mass  $M$ , radius  $R$  and moment of inertia  $I$ . A block of mass  $m$  is attached from one end of the string and is held at rest. The block is then released.

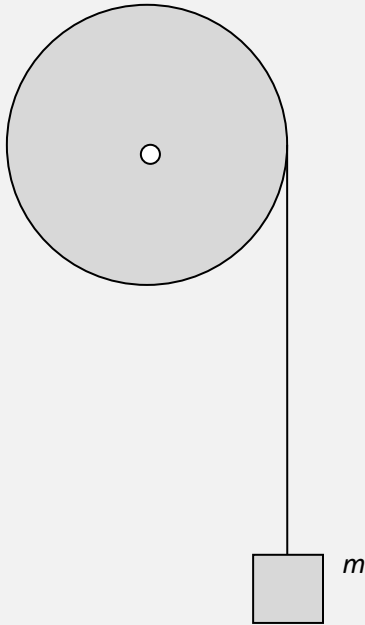

What is the acceleration of the block?

- A  $\frac{g}{1 + \frac{I}{MR^2}}$       B  $\frac{g}{1 + \frac{I}{mR^2}}$       C  $\frac{mg}{M}$       D  $g$
- 91 What is meant by “proper length” in relativity?

- A The correctly measured length of an object.
- B The length of an object when it is moving at relativistic speed.
- C The length of an object when it is at rest.
- D The length of an object when its ends are measured at the same time.

- 92 A passenger on a train going past a train station sees that a light at the station flashes every second according to her clock. An observer is stationary at the train station. Who measures the proper time interval between the flashes of the light and what does the station observer measure for the time interval between flashes?

	Measures proper time	Station observer measurement
A	Passenger	Less than 1 second
B	Passenger	More than 1 second
C	Station observer	Less than 1 second
D	Station observer	More than 1 second

- 93 The length of a rod at rest is 1.0 m and 0.50 m when moving with speed  $v$  past an observer. What is  $v$ ?

A  $\frac{1}{2}c$       B  $\frac{\sqrt{3}}{2}c$       C  $\frac{\sqrt{3}}{4}c$       D  $\frac{3}{4}c$

- 94 A cube whose sides have proper length  $a$ , moves with relativistic speed relative to an observer P in the direction shown.

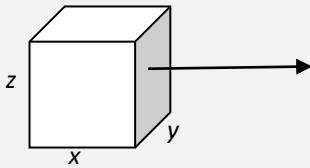

Observer P measures the length of each side to be  $x$ ,  $y$  and  $z$ . Three statements are made:

- I  $x = a$   
 II  $y = a$   
 III  $z = a$

Which is correct?

- A I and II  
 B I and III  
 C II and III  
 D I, II and III
- 95 Relative to the ground, rocket X moves to the left with speed  $0.80c$  and rocket Y moves to the right with speed  $0.50c$ . What is the speed of rocket Y relative to rocket X?
- A  $\frac{1.3}{1.4}c$       B  $\frac{0.3}{1.4}c$       C  $1.3c$       D  $0.3c$

- 96 A spacecraft moving with speed  $v$  relative to the Earth leaves Earth on its way to a space station S, at distance  $d$  according to Earth. The space station is at rest relative to the Earth. How long did the trip take according to Earth, spacecraft and space station clocks?

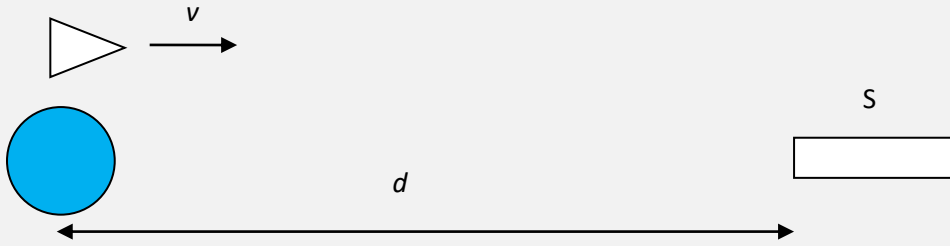

	Earth	Spacecraft	Space station
A	$\frac{d}{v}$	$\frac{d}{v\gamma}$	$\frac{d}{v}$
B	$\frac{d}{v}$	$\frac{d}{v\gamma}$	$\frac{d}{v\gamma}$
C	$\frac{d\gamma}{v}$	$\frac{d}{v}$	$\frac{d\gamma}{v}$
D	$\frac{d\gamma}{v}$	$\frac{d}{v}$	$\frac{d}{v}$

- 97 The spacetime diagram shows the axes ( $x, ct$ ) of a reference frame S and those of a reference frame  $S'$  moving relative to S. An event E is shown. Which event is simultaneous with E in the frame  $S'$ ?

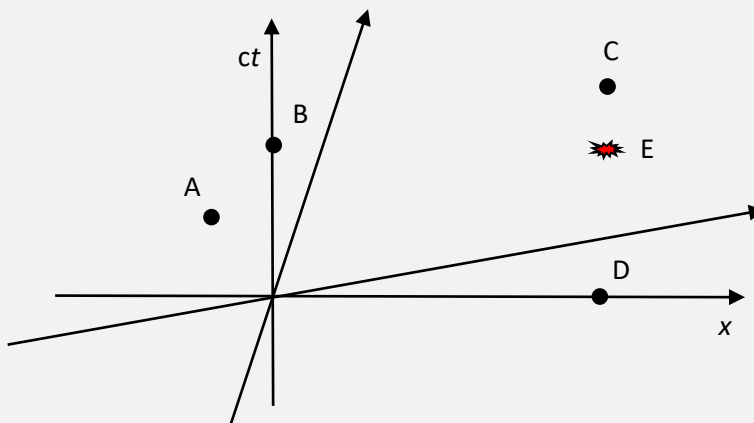

- 98 The spacetime diagram shows 4 worldlines. The dotted lines are the worldlines of a photon. Which worldline is **not** possible?

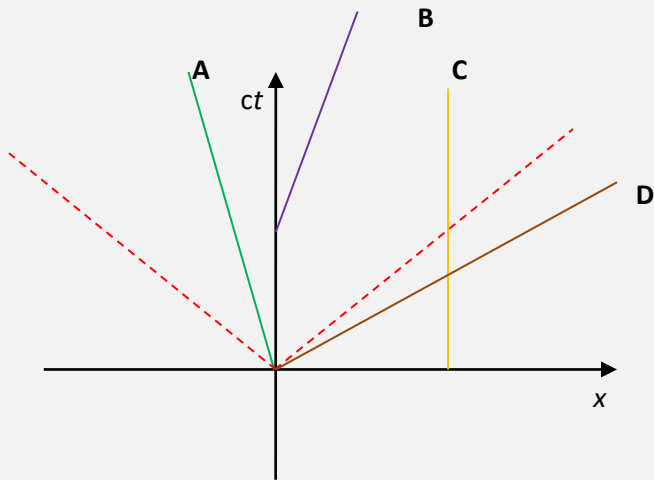

- 99 A reference frame  $S'$  moves relative to  $S$  with velocity  $v$ . The coordinates of an event  $E$  in  $S$  are  $(x=1, ct=0)$ . What are the coordinates  $(x', ct')$  of  $E$  in  $S'$ ?

	$x'$	$ct'$
A	1	$\gamma$
B	1	$-\frac{\gamma v}{c^2}$
C	$\gamma$	$\gamma$
D	$\gamma$	$-\frac{\gamma v}{c}$

- 100** A rocket flies over a space station at relativistic speed. Two lights are turned on at the front (F) and rear (R) of the space station. The lights are turned on at the same time according to space station clocks. At that instant the rocket is above the midpoint of the space station.

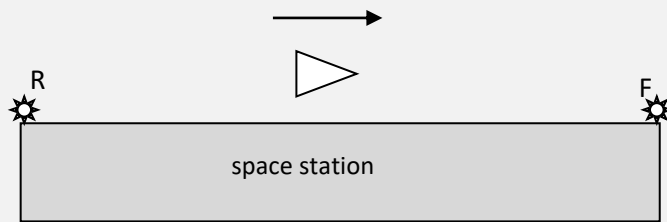

diagram from the space station's viewpoint

According to the rocket, which light turns on first and which light is seen first by the rocket observer?

	Turned on first	Seen first from
A	F	F
B	F	R
C	R	F
D	R	R

## TOPIC A

## ANSWERS

1	D	26	A	51	B	76	B
2	B	27	D	52	D	77	A
3	A	28	D	53	B	78	C
4	C	29	B	54	B	79	D
5	D	30	A	55	D	80	D
6	C	31	B	56	C	81	B
7	C	32	C	57	D	82	A
8	C	33	B	58	C	83	B
9	A	34	A	59	A	84	C
10	D	35	D	60	A	85	A
11	B	36	B	61	C	86	D
12	C	37	D	62	D	87	C
13	B	38	A	63	D	88	C
14	B	39	D	64	B	89	C
15	A	40	A	65	A	90	B
16	B	41	C	66	C	91	C
17	C	42	A	67	B	92	C
18	C	43	D	68	B	93	B
19	D	44	A	69	B	94	C
20	B	45	A	70	C	95	A
21	B	46	C	71	D	96	A
22	B	47	C	72	D	97	A
23	D	48	D	73	C	98	D
24	D	49	B	74	C	99	D
25	A	50	B	75	D	100	A